

METHODIST GIRLS' SCHOOL
Founded in 1887



MID-YEAR EXAMINATION 2021
PRIMARY 6
SCIENCE
BOOKLET A

Total Time for Booklets A and B: 1 hour 45 minutes

INSTRUCTIONS TO CANDIDATES

Do not turn over this page until you are told to do so.

Follow all instructions carefully.

Answer all questions.

Shade your answers in the Optical Answer Sheet (OAS) provided.

Name: _____ ()

Class: Primary 6. _____

Date : 11 May 2021

This booklet consists of 20 printed pages including this page.

For each question from 1 to 28, four options are given. One of them is the correct answer. Make your choice (1, 2, 3 or 4) and shade your answer on the Optical Answer Sheet.

[56 marks]

- 1 Study the classification chart as shown below carefully.

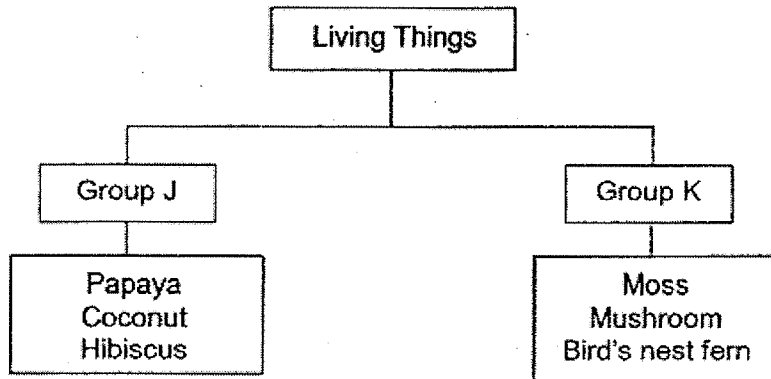

Which of the following headings correctly represents Groups J and K?

	Group J	Group K
(1)	Flowering plants	Non-flowering plants
(2)	Reproduce from seeds	Reproduce from spores
(3)	Fruit has a few seeds	Fruit has only one seed
(4)	Can make its own food	Cannot make its own food

- 2 Study the classification chart below.

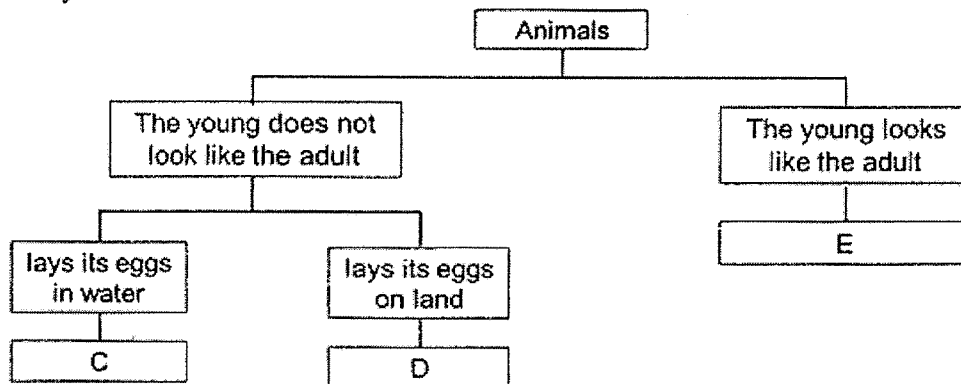

Which of the following represents animals C, D and E?

	C	D	E
(1)	frog	cockroach	chicken
(2)	mosquito	butterfly	grasshopper
(3)	frog	mosquito	cockroach
(4)	mosquito	chicken	grasshopper

(Go on to the next page)

3 The diagram shows how water and sugar move through different parts, S, T, U and V, of a plant.

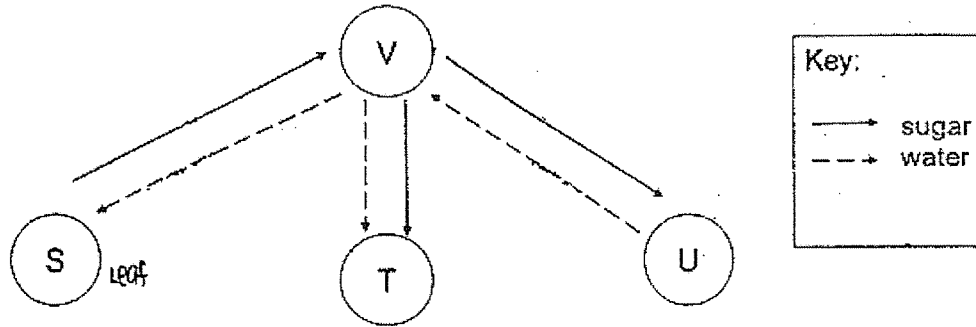

Which of the letters represent the parts of the plant correctly?

	Root	Stem	Leaf
(1)	T	V	U
(2)	U	V	S
(3)	U	S	V
(4)	V	S	T

4 The diagram below shows different types of cells.

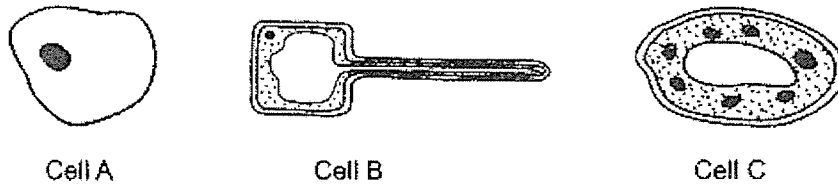

Ken made the following statements.

- X Cells B and C have a cell membrane each but Cell A does not.
- Y Cell C has chloroplasts but Cells A and B do not.
- Z Cell A is an animal cell but Cells B and C are plant cells.

Which statement(s) is/are correct?

- (1) Y only
- (2) X and Y only
- (3) X and Z only
- (4) Y and Z only

5 A flower with both male and female parts is shown in the diagram below.

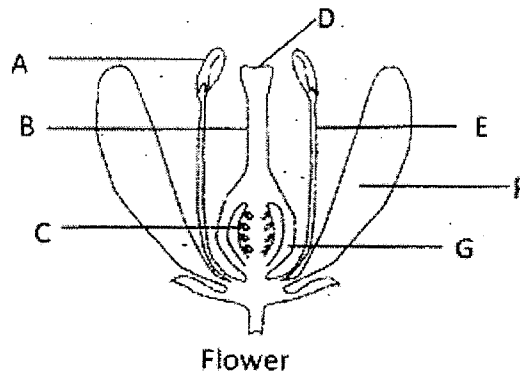

Which letters represent the female reproductive parts of the flower?

- (1) A and E only
- (2) C and G only
- (3) A, E, F and G only
- (4) B, C, D and G only

6 The map below shows the seed dispersal pattern of three types of plants, □, △ and ×, growing in an area.

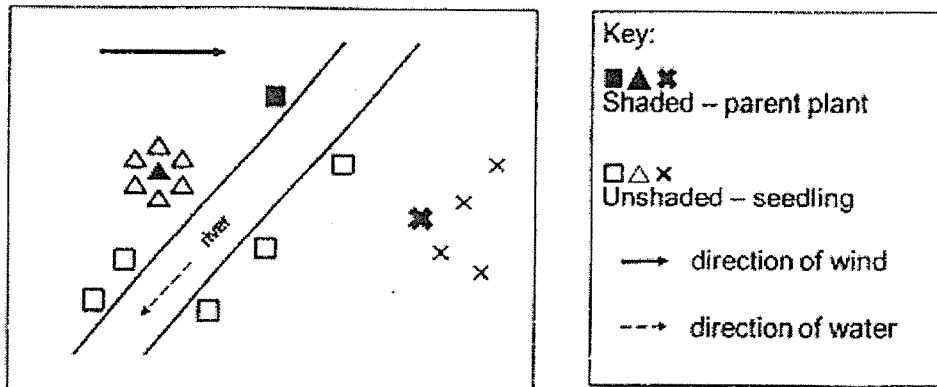

Based on the map, which one of the following describes the characteristics of the fruit or seed of the plants?

	Plant □	Plant △	Plant ×
(1)	pod-like structure	stiff hair	fibrous husk
(2)	pod-like structure	fibrous husk	wing-like structure
(3)	fibrous husk	pod-like structure	wing-like structure
(4)	stiff hair	juicy flesh	pod-like structure

- 7 The diagram below shows how substances R and S are transported in a human body.

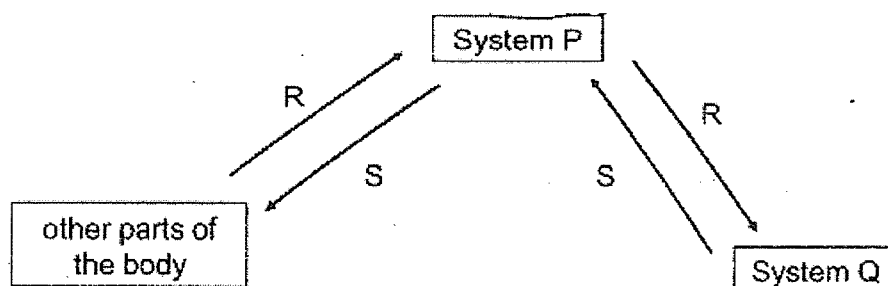

What are systems P and Q and substances R and S?

	System P	System Q	Substance R	Substance S
(1)	circulatory	respiratory	carbon dioxide	oxygen
(2)	respiratory	circulatory	oxygen	carbon dioxide
(3)	circulatory	respiratory	oxygen	carbon dioxide
(4)	respiratory	circulatory	carbon dioxide	oxygen

- 8 A group of scientists observed the conditions in three different habitats, B, C and D, and recorded their observations in the table below.

Habitat	Range of temperature of surroundings (°C)	Amount of light at 12 pm (unit)	Amount of moisture (%)
B	30 to 35	100	90
C	29 to 34	105	85
D	0 to 3	2000	10

Based on their observations, which of the following conclusions is/are correct?

- W Most of the organisms in Habitat D live in water.
- X Organisms in Habitat B can most probably survive in Habitat C.
- Y Organisms in Habitat B can most probably survive in dark and damp environments.

- (1) Y only
- (2) W and X only
- (3) W and Y only
- (4) X and Y only

9 Three statements were made about decomposers.

- A All decomposers are microorganisms.
- B Decomposers make their own food in the presence of light.
- C Decomposers help to break down animal wastes into simpler substances.

Which statement(s) is/are correct?

- (1) C only
- (2) A and B only
- (3) B and C only
- (4) A, B and C

10 Study the food chain below carefully.

plant \longrightarrow caterpillar \longrightarrow bird

After the birds were removed, some events (A, B, C and D) took place.

- A Population of plants decreased.
- B Population of caterpillars decreased.
- C Caterpillars did not have enough food.
- D Population of caterpillars increased sharply.

Which one of the following shows the correct order of events?

- (1) B \rightarrow A \rightarrow C \rightarrow D
- (2) C \rightarrow B \rightarrow A \rightarrow D
- (3) D \rightarrow C \rightarrow B \rightarrow A
- (4) D \rightarrow A \rightarrow C \rightarrow B

- 11 Zen covered a part of the leaf with a piece of aluminium foil as shown in the diagram below.

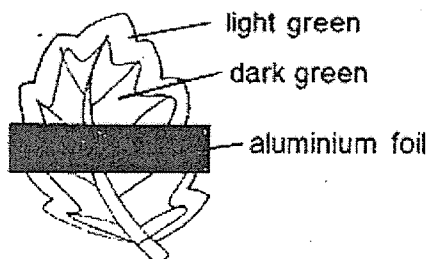

After a day, she plucked the leaf and conducted iodine tests on four different areas, P, Q, R and S, on the leaf and recorded her results in the table below.

Area	Results of iodine test
P	traces of dark blue
Q	dark blue
R	dark blue
S	brown

Based on the results obtained, which one of the following diagrams correctly shows areas P, Q, R and S on the leaf?

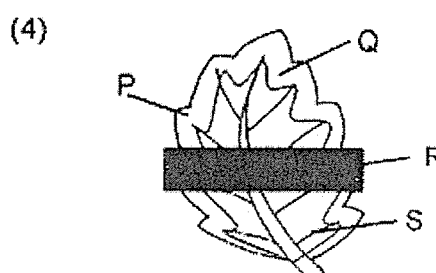
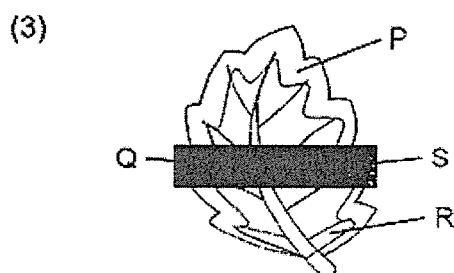
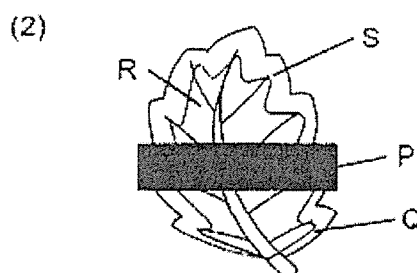
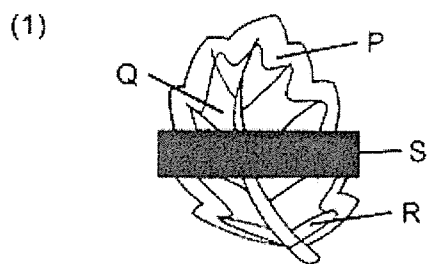

- 12 Kate cut out four different shapes from the same type of sponge. She pierced a stick through each shape and displayed them in trays as shown in the diagram below.

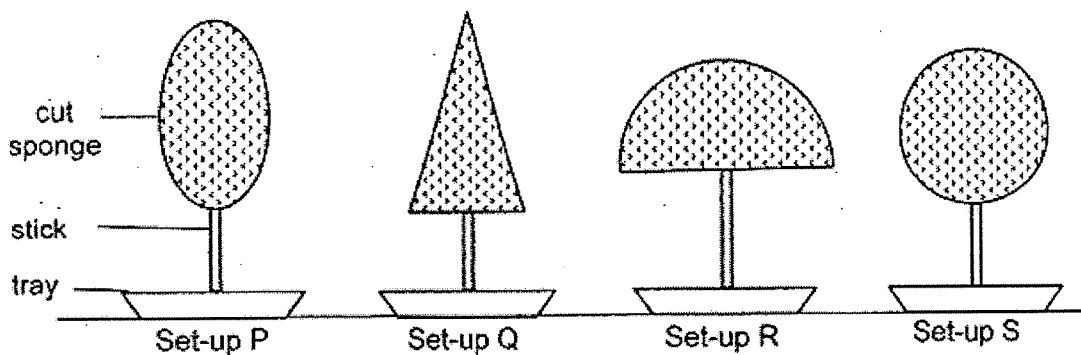

She sprinkled 50 g of flour over the top of each shape and measured the amount of flour collected in each tray. The results are recorded in the table below.

Set-up	P	Q	R	S
Amount of flour collected in the tray (g)	32	45	13	27

During winter, if trees collect too much snow, there is a high chance that their branches will crack and collapse onto the ground. Based on the results of Kate's experiment, which of the following trees can most likely adapt to survive in a habitat with a large amount of snow?

(1)

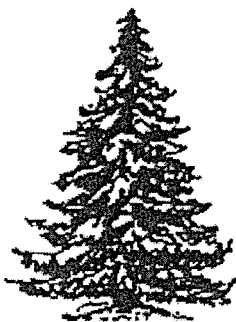

(2)



(3)



(4)

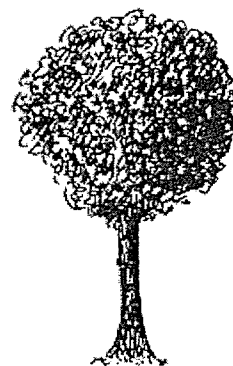

(Go on to the next page)

- 13 Corals are found in the sea. Their poisonous tentacles are used to capture other animals. They have translucent bodies which protect them from harmful ultraviolet rays. They attach themselves to rocks in order to form a group which increases their chances of reproduction.

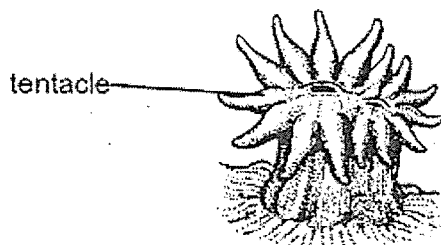

A coral

Which of the following adaptations are identified correctly?

	Structural Adaptation	Behavioural Adaptation
(1)	attaches itself to a rock to form a group	translucent body
(2)	translucent body	poisonous tentacles
(3)	poisonous tentacles	attaches itself to a rock to form a group
(4)	can breathe in water	translucent body

- 14 The diagram below shows a set of earphones attached to a handphone.

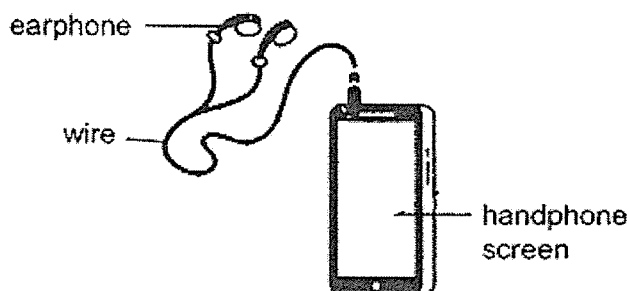

What are the properties that make the materials suitable to make the wire and the handphone screen?

Properties of materials		
	Wire	Handphone screen
(1)	poor conductor of electricity	light cannot pass through
(2)	good conductor of electricity	absorbs water
(3)	flexible	light can pass through
(4)	waterproof	good conductor of electricity

(Go on to the next page)

15 Study the flow chart below.

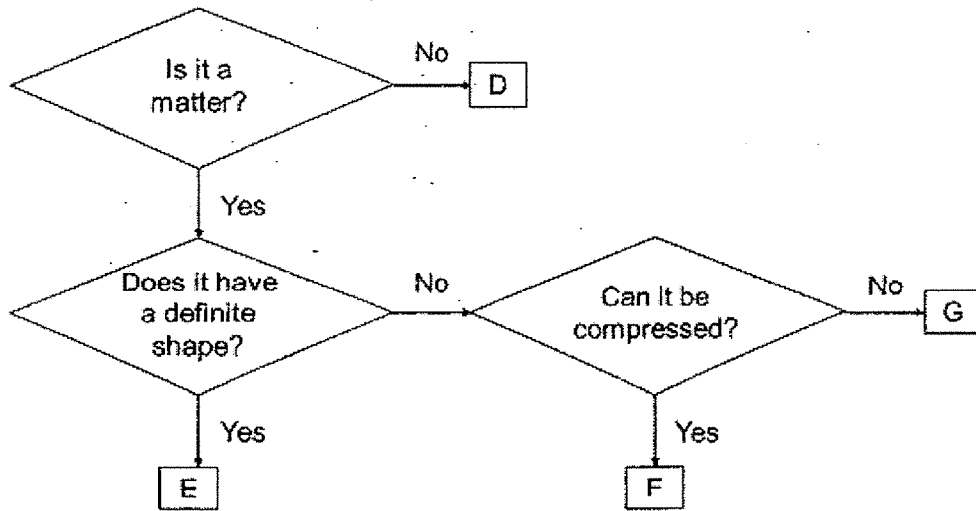

Which one of the following correctly represents F and G?

	F	G
(1)	mist	steam
(2)	rain	cloud
(3)	cloud	rain
(4)	steam	cloud

(Go on to the next page)

16 Jean cut out three different shapes of the same height from a piece of cardboard. She wanted to observe the shadow formed by the shapes when they were arranged in a straight line. The diagram below shows the set-up with the shapes labelled A, B and C.

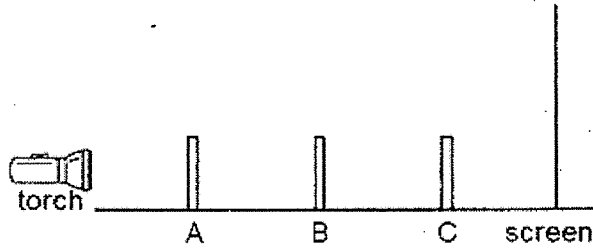

The shadow formed by the three objects on the screen is shown below.

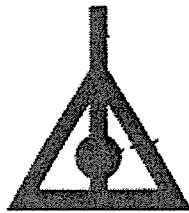

Which of the following shows the shapes of A, B and C correctly?

- | | Shape A | Shape B | Shape C |
|-----|---------|---------|---------|
| (1) | | | |
| (2) | | | |
| (3) | | | |
| (4) | | | |

(Go on to the next page)

- 17 The table below shows the melting and boiling points of substances A and B.

Substance	A	B
Melting Point ($^{\circ}\text{C}$)	20	5
Boiling Point ($^{\circ}\text{C}$)	110	90

At which temperature are substances A and B in the same state of matter?

	Temperature ($^{\circ}\text{C}$)
W	15
X	45
Y	100
Z	115

- (1) W and X only
 (2) Y and Z only
 (3) X and Z only
 (4) W and Y only
- 18 A copper rod was taken out from a refrigerator and placed immediately into a basin of hot water as shown below.

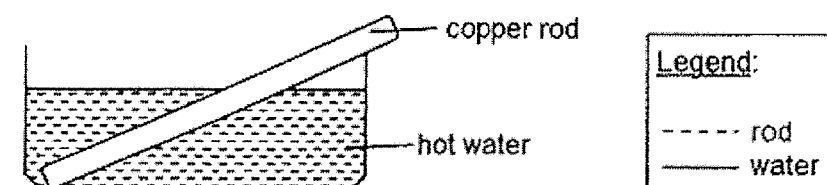

Which one of the following graphs below shows the temperature of the copper rod and water over a period of time?

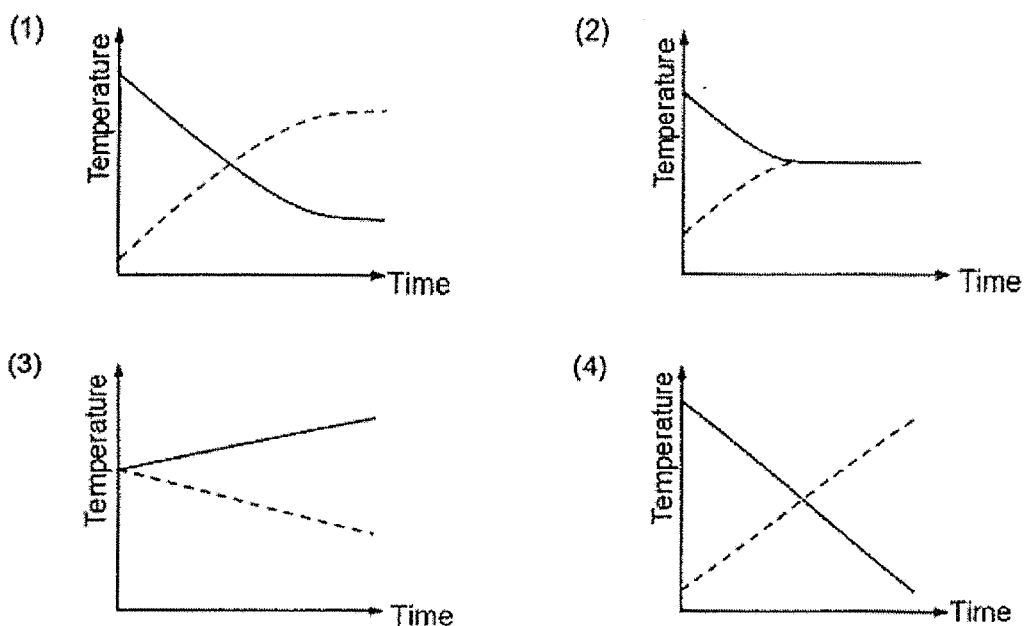

(Go on to the next page)

- 19 Rahim and his friends conducted an experiment. Rahim poured the same amount of water into three different containers, X, Y and Z. He then placed the containers under the sun. The graph shows the amount of water left in each container over time.

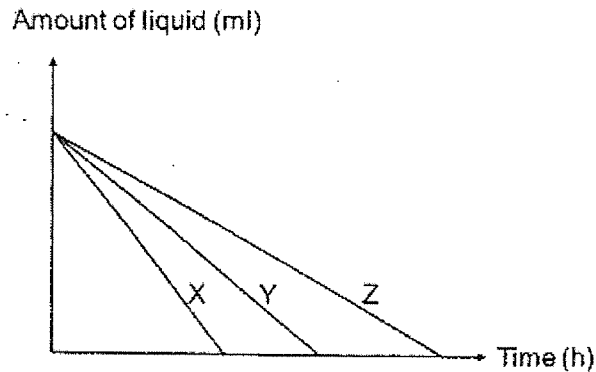

After the experiment, Rahim and his friends made the following statements.

- A Water in container X has the highest rate of evaporation.
- B Water in container Z has the smallest exposed surface area.
- C Water in container Y has a greater exposed surface area than container X.

Which statement(s) is/are correct based on the graph above?

- (1) A only
 - (2) B only
 - (3) A and B only
 - (4) A and C only
- 20 The diagrams below show four different electrical circuits, A, B, C and D.

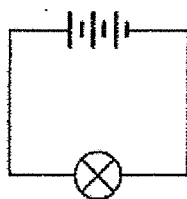

circuit A

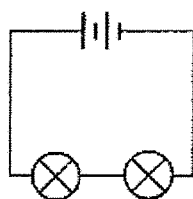

circuit B

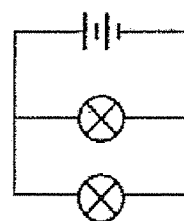

circuit C

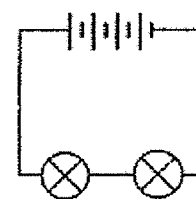

circuit D

In which of the above circuits do the bulbs have the same brightness?

- (1) A and B
- (2) A and D
- (3) B and C
- (4) C and D

21 Kate has a toy carousel operating on batteries. It has a platform turned by a motor, a canopy which can light up and a speaker which plays music.

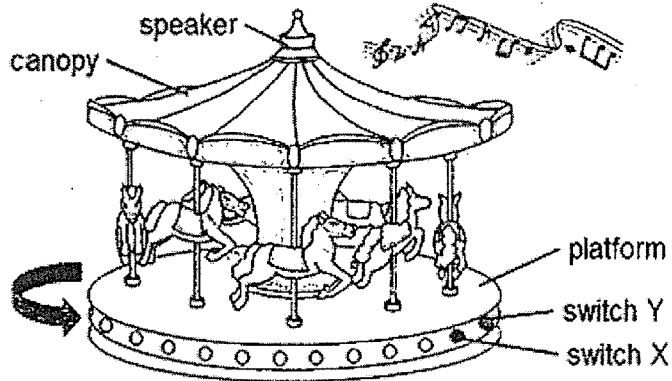

Kate turned on the two switches, X and Y, and her observations of the toy carousel are shown below.

Switched on	Observation
Both X and Y	Canopy lighted up Platform turned Speaker played music
X only	Canopy did not light up Platform turned Speaker played music
Y only	Canopy light up Platform turned Speaker did not play music

Legend:

(S) speaker

(M) motor

Which of the following shows the arrangement of the electrical circuit in the toy carousel?

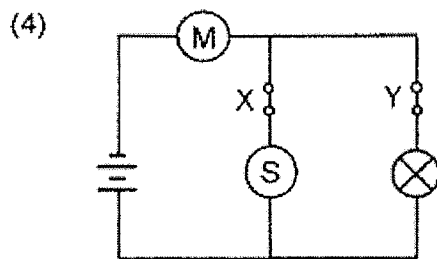
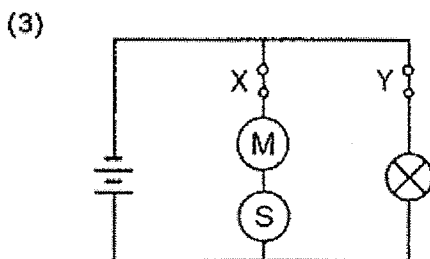
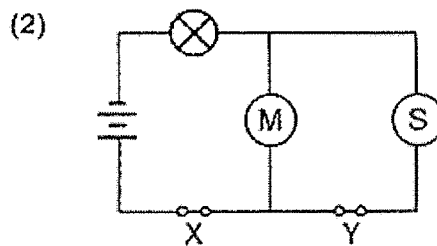
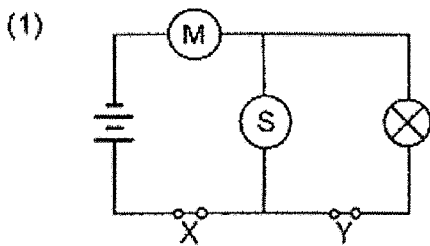

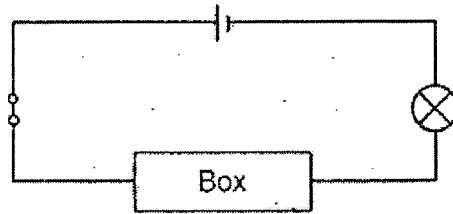

22 A box is connected to a circuit tester as shown below.

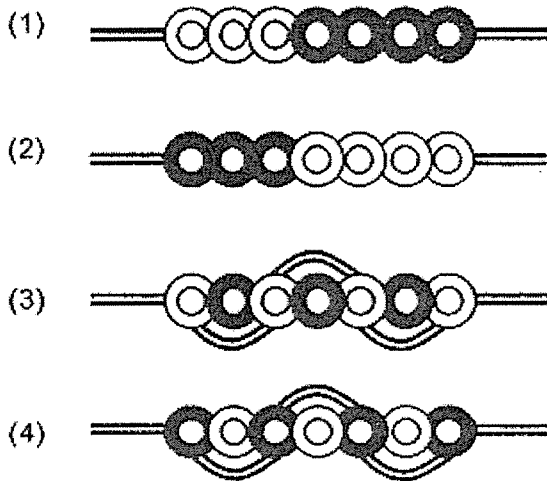

When the circuit is closed, the bulb lights up. Which one of the following correctly shows what is in the box?



Legend:

-  metal ring
-  plastic ring
-  metal wires

23 Ali wants to find out if an object has more gravitational potential energy if it is dropped from a greater height onto a block of plasticine.

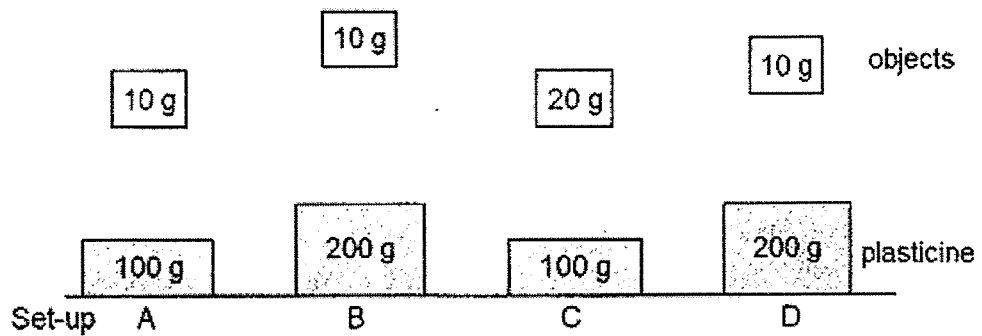

Which two set-ups should he use to conduct a fair test?

- (1) A and C
- (2) A and B
- (3) B and C
- (4) B and D

- 24 Muthu took a roller coaster ride with his friend at an amusement park. The roller coaster car travelled from position P to T.

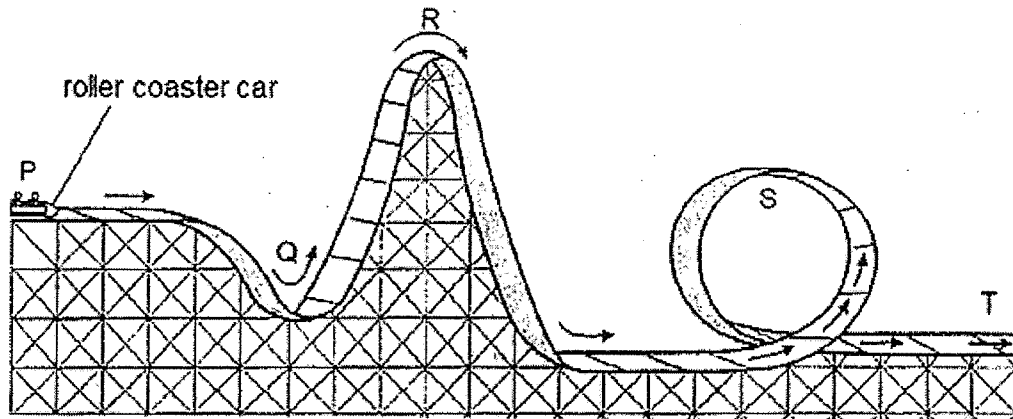

Which of the following statement(s) correctly describe(s) the roller coaster car?

- A The car possesses kinetic energy at Q and S.
 - B The car has more gravitational potential energy at R than at S.
 - C There is less frictional force acting on the car at T than other positions.
- (1) A only
 (2) A and B only
 (3) A and C only
 (4) B and C only

- 25 A wooden block slid down a plastic slope after it was released from the top as shown in the diagram below.

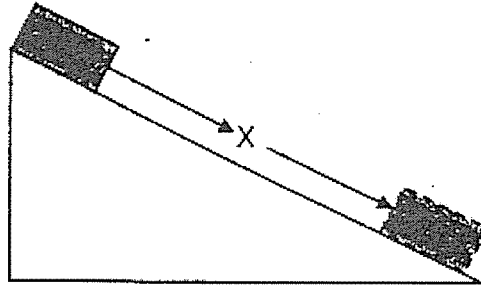

The graph below shows the amount of the different types of energy of the block at position X.

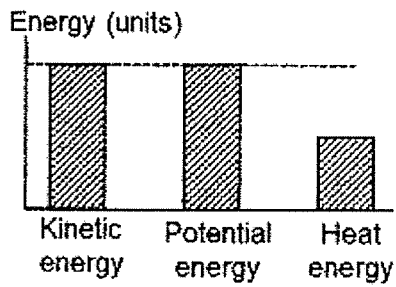

The experiment was repeated with the surface of the slope pasted over with sandpaper.

Which one of the following graphs shows the amount of different types of energy of the block at position X?

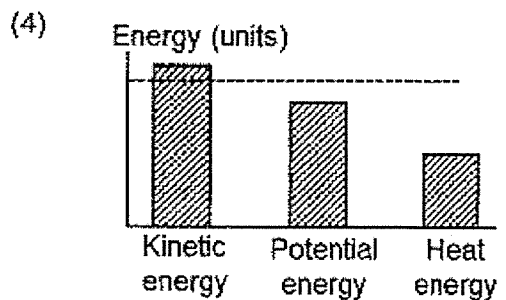
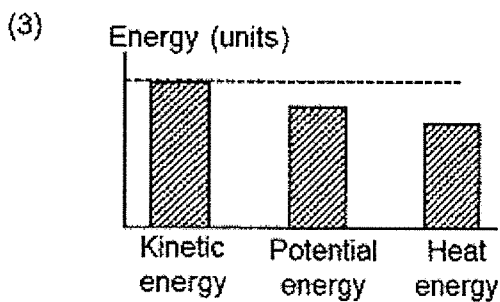
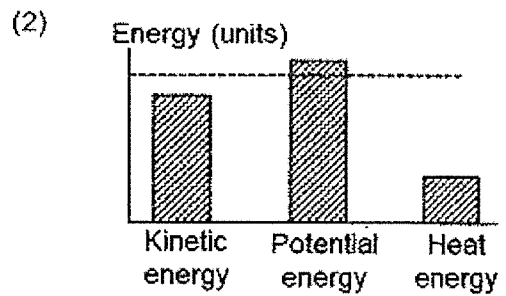
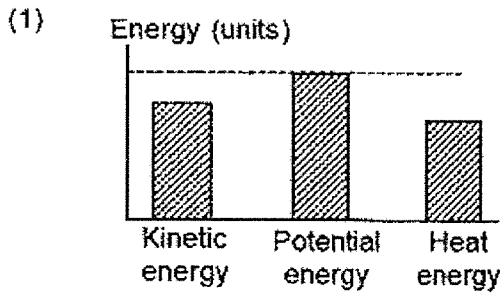

- 26 Evan carried out an experiment and hung Magnet X from a spring. The original length of the spring was 6 cm. He placed Magnet Y below Magnet X and observed the length of the spring as shown in the diagram below.

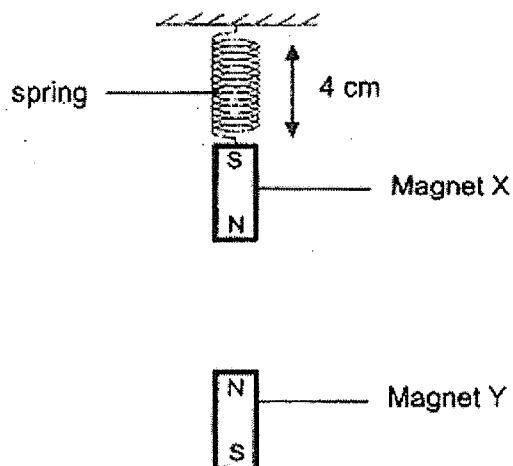

Next, he flipped Magnet Y over so that its south pole was facing Magnet X. What would be the likely length of the spring now?

- (1) 2 cm
- (2) 3 cm
- (3) 4 cm
- (4) 7 cm

- 27 Sue attached a spring balance to two boxes, A and B, of the same mass as shown below.

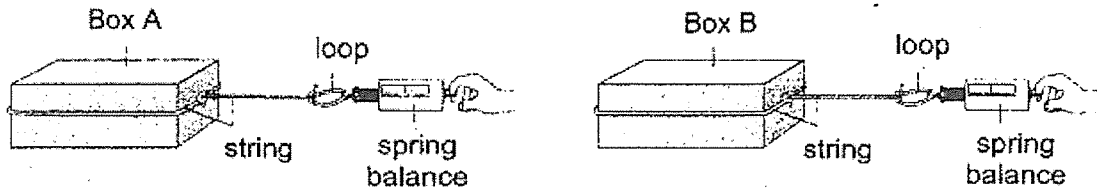

She pulled the spring balances slowly on a table until the boxes move with a constant speed. She recorded the amount of force required to pull each box in the table below.

	Amount of force (units)
Box A	25
Box B	70

Which of the following statements explains the difference in the amount of force required to pull the boxes?

- X The mass of Box A was less than Box B.
 - Y Lubricant was applied to the bottom of Box A.
 - Z Box A was made of a rougher material than Box B.
- (1) X only
- (2) Y only
- (3) X and Z only
- (4) Y and Z only

28 The diagram below shows Zachary jumping up and down on a trampoline.

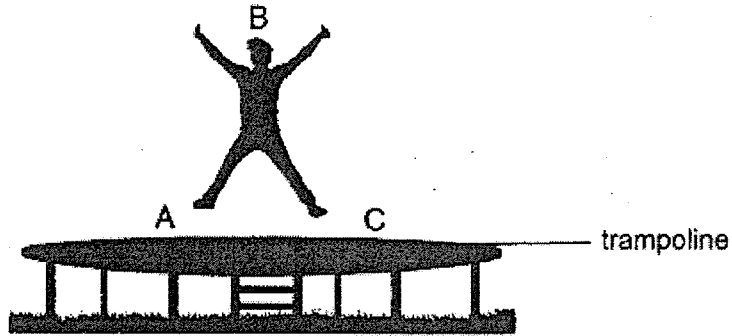

Which of the following graphs shows the amount of gravitational force acting on him as he jumps from positions A to B and lands at C?

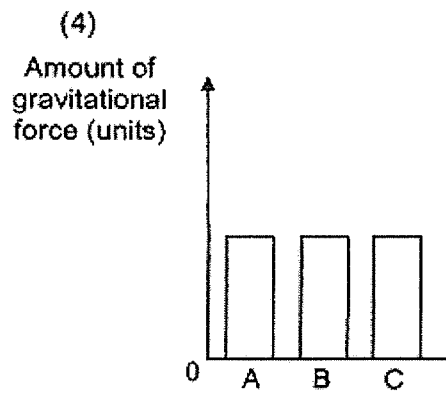
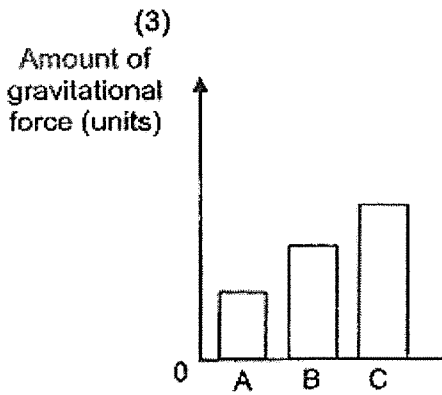
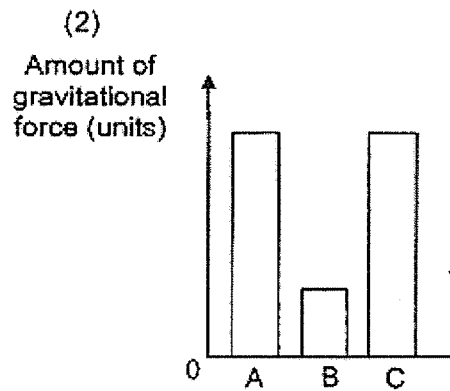
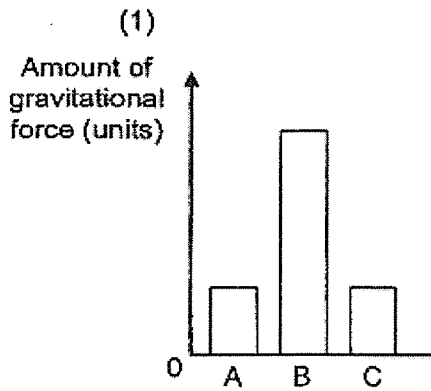

METHODIST GIRLS' SCHOOL
Founded in 1887



MID-YEAR EXAMINATION 2021
PRIMARY 6
SCIENCE

BOOKLET B

Total Time for Booklets A and B: 1 hour 45 minutes

INSTRUCTIONS TO CANDIDATES

Do not turn over this page until you are told to do so.
Follow all instructions carefully.
Answer all questions.

Name:

Class: Primary 6. _____

Date : 11 May 2021

Booklet A	56
Booklet B	44
Total	100
Parent's Signature	

This booklet consists of 17 printed pages including this page.

For questions 29 to 40, write your answers in this booklet. The number of marks available is shown in brackets [] at the end of each question or part question. [44 marks]

- 29 The diagram below shows the human respiratory system. Exchange of gases takes place at the air sacs.

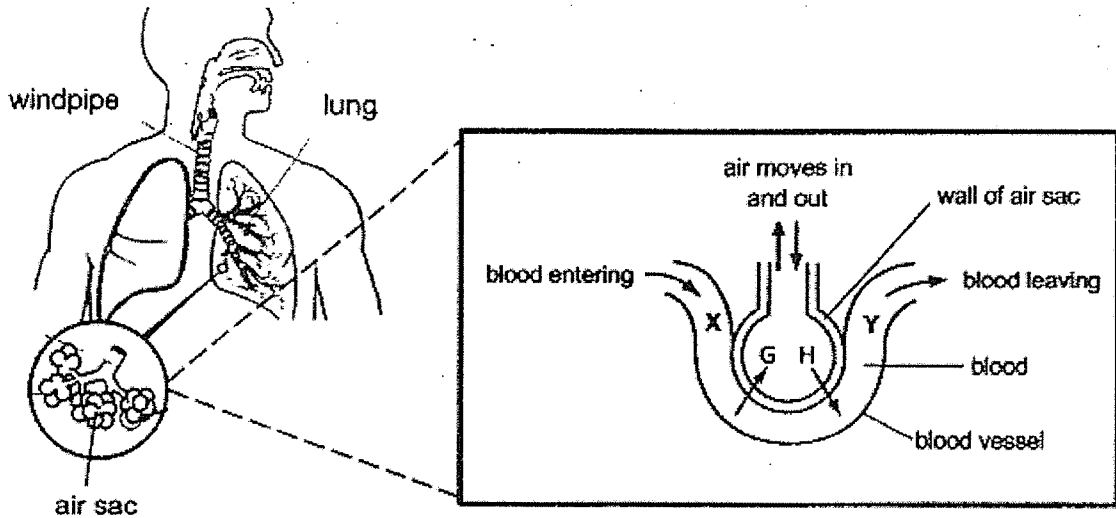

Human respiratory system

Magnified view of air sac and blood vessel

The graph below shows the amount of two gases, G and H, found in parts X and Y.

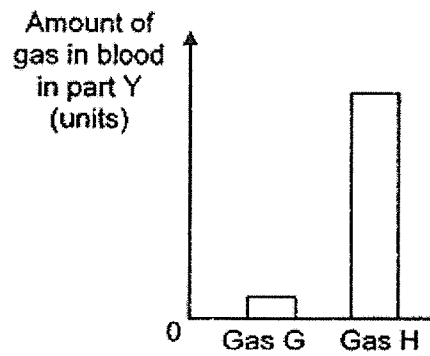
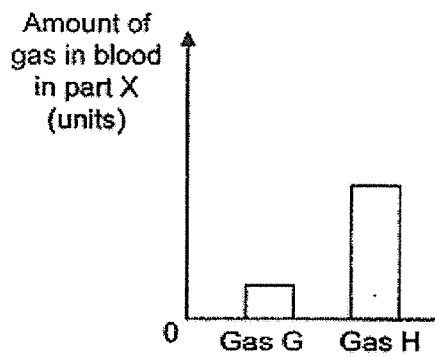

- (a) Identify gases G and H.

[1]

Gas G: _____

Gas H: _____

(Go on to the next page)

Mr Ang and Mr Chen took part in a health study. One of them is a smoker. Smoking can cause substances to be trapped in the walls of the air sacs in the lungs. Both of their heart rates at rest over a period of time were measured as shown in the graph below.

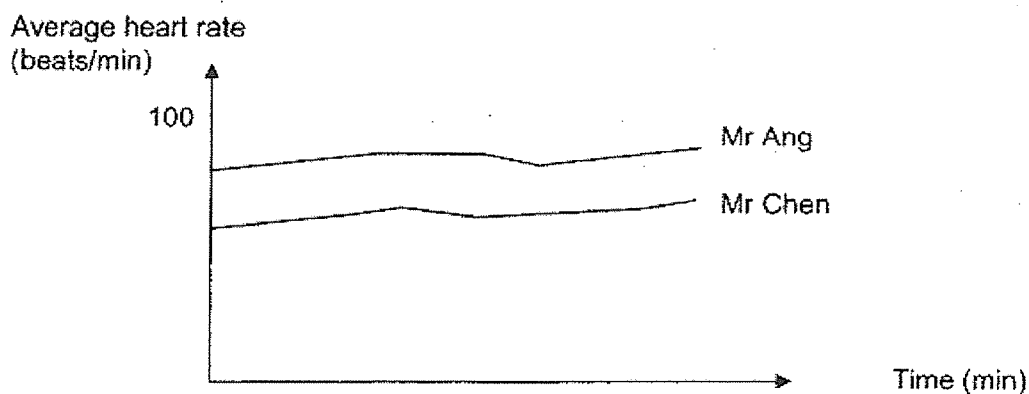

(b) How does smoking affect the rate of gaseous exchange in the air sacs of the lungs? [1]

(c) Based on the graph above, is Mr Ang or Mr Chen more likely to be a smoker? Explain your answer. [2]

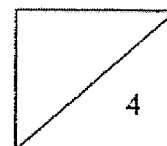

(Go on to the next page)

30 A group of scientists conducted an experiment to find out if the size of food affects the rate of digestion. Their results are shown in the graph below.

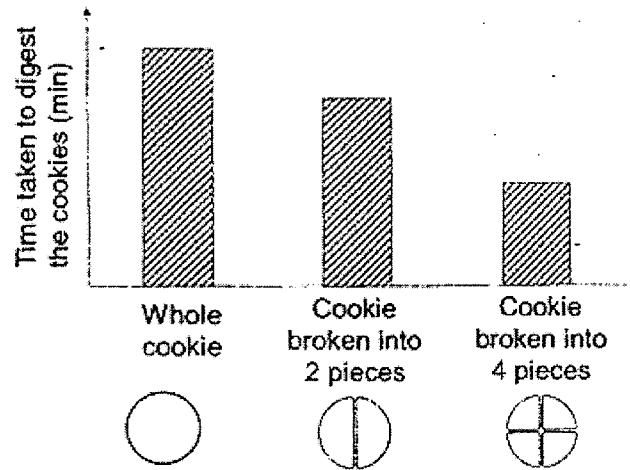

(a) Based on the results of the experiment, how does the size of food affect the rate of digestion? Explain your answer. [2]

Due to the loss of teeth, Uncle Meng bought a set of false teeth, also known as dentures. He wears it inside his mouth while he eats.

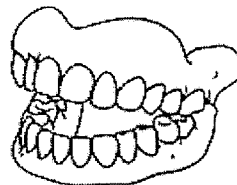

dentures

(b) How do the dentures help him to digest food better? [1]

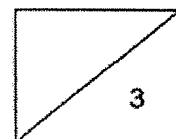

(Go on to the next page)

31 The diagram below shows a flower that has developed into a fruit.

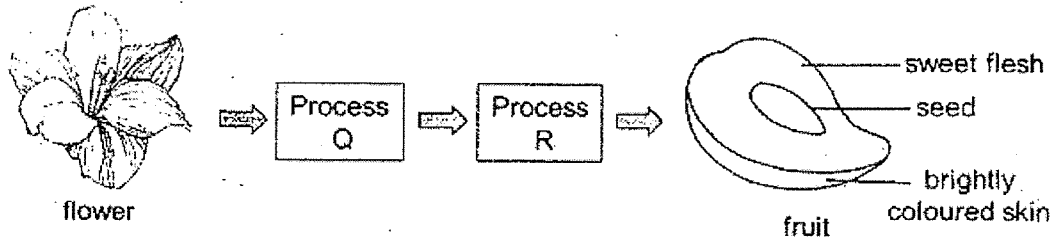

(a) Identify processes Q and R in order for the flower to become a fruit. [1]

Process Q: _____

Process R: _____

(b) State the part of the flower that the seed developed from. [1]

(c) Describe how the seed is dispersed. [1]

(d) Explain why a new plant grown from the seed will also bear fruits with sweet flesh. [1]

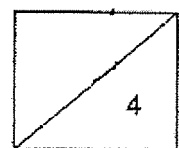

(Go on to the next page)

- 32 Mag set up an experiment to study the effect of coloured lights on the rate of photosynthesis in plants. At the end of 5 days, she measured the amount of gas X collected in the test tube.

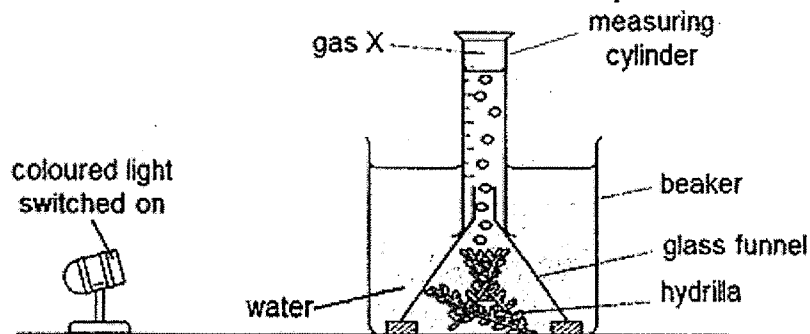

The table below shows her results.

Colour of light	Amount of gas collected (cm ³)
Red	16
Blue	22
Green	7
Yellow	30

- (a) What is gas X? [1]

- (b) Based on the above results, which coloured light resulted in the highest rate of photosynthesis? Explain your answer. [1]

Mag shifted the set-up into a dark room and conducted another experiment.

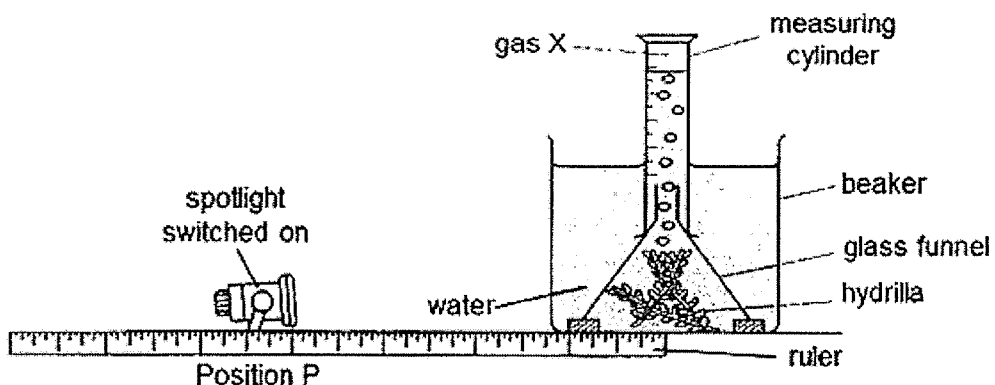

(Go on to the next page)

Without removing anything from the beaker, Mag changed variable Z and measured the amount of gas X collected. The graph below shows her results.

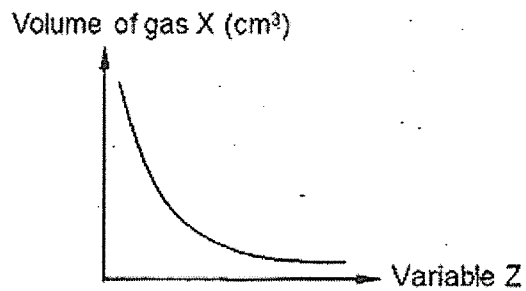

- (c) What would variable Z be? [1]

- (d) Mag conducted the experiment with the spotlight placed at position P and she added ten water snails next to the hydrilla in the beaker. The amount of gas X collected increased. Give a reason for her observation. [1]

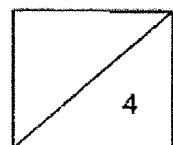

(Go on to the next page)

- 33 In an experiment, Timothy wanted to find out if the number of fishes affect the amount of oxygen dissolved in the water. He set up three tanks, A, B and C, with the same type of fish. He placed them at the same location.

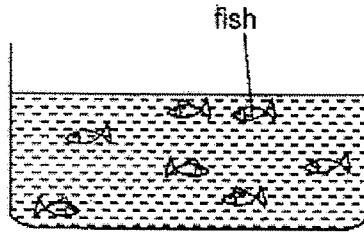

At the start, the amount of oxygen dissolved in the water for each tank was 60 units. After some time, he recorded the amount of oxygen dissolved in the water in the table below.

Tank	Number of fish	Amount of oxygen dissolved in water (units)
A	14	20
B	7	40
C	0	60

- (a) What is the purpose of Tank C? Explain your answer. [1]

Timothy added some aquatic plants to Tank A. A few days later, he observed organism Z growing and reproducing inside Tank A.

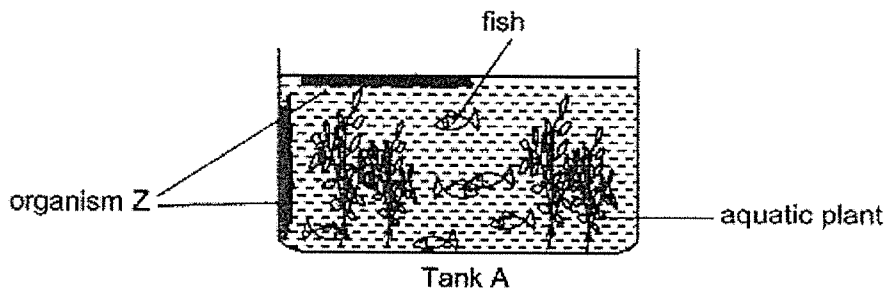

- (b) If organism Z reproduces at a very fast rate and covers the surface of the water and the walls of the tank, how would this affect the aquatic plants in the tank? Explain your answer. [2]

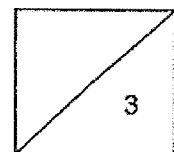

- 34 Natalie observed the population of five types of organisms, P, Q, R, S and T, living in a field community. She kept five of each type of organism in different containers, 1, 2 and 3, over a period of time. After 5 days, her observations are recorded in the table below.

Container	Organisms kept together (Day 1)	Observations (Day 5)
1	P, Q and R	Only 5 P and 5 R are alive
2	S and T	Only 5 S are alive
3	P, R and T	Only 5 T are alive

- (a) Based on the above results, construct a food web showing the relationships between the five organisms by filling in P, Q, S and T, in the boxes below. [1]

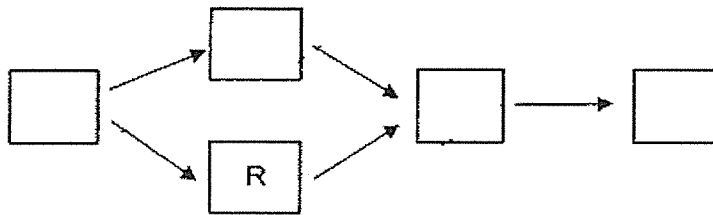

- (b) The field community experiences shorter daylight hours in winter. Explain how this affects the population size of organism R in winter. [2]

- (c) Natalie observed a decrease in the plant population in the field community. Other than adding more plants, which of the above organisms should she add to the community in order to increase the plant population? Explain why. [1]

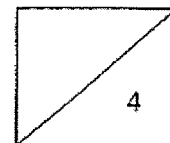

- 35 Diana set up an experiment using the apparatus as shown in the diagram below. The disc has a cardboard cover that can be adjusted to expose different surface area of the transparent sheet in its centre.

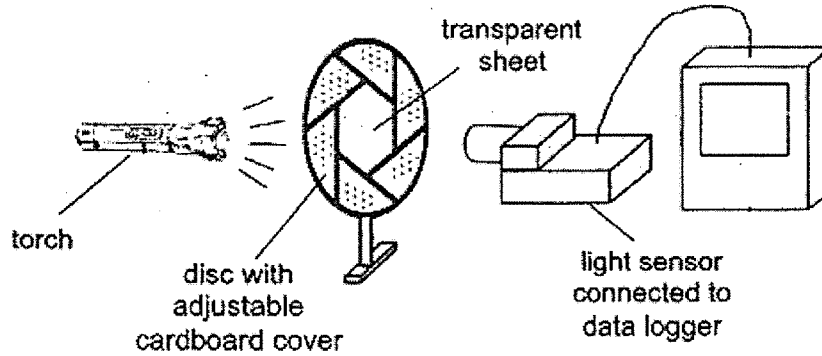

She recorded the amount of light detected by the light sensor when the adjustable cover was moved to change the surface area of the transparent sheet.

Surface area of transparent sheet (cm ²)	Amount of light detected (unit)
100	500
75	240
50	170
25	10

- (a) How does the increase in surface area of the transparent sheet affect the amount of light detected? [1]

Snake A is non-poisonous, hunts at night and has eyes that are sensitive to the presence of light. The pupil controls the amount of light entering the eye. The size of its pupil changes according to the amount of light in its surroundings.

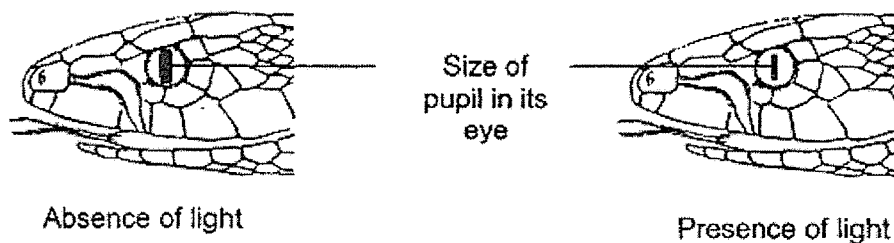

(Go on to the next page)

The graph below shows the changes in the size of its pupil according to the amount of light in its surroundings.

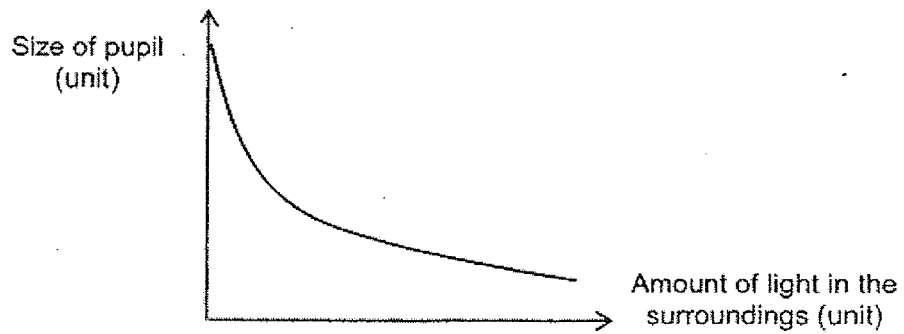

- (b) Explain how Snake A is adapted to see better at night. [1]

Snake A has body colour and patterns that look similar to Snake B, which is highly poisonous.

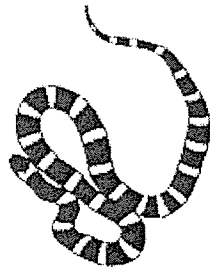

Snake A

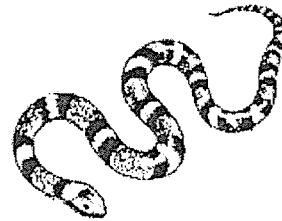

Snake B

- (c) Why is it an advantage for Snake A to resemble Snake B? [1]

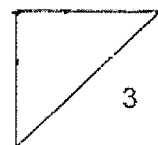

(Go on to the next page)

- 36 A scientist opened the freezer door to take out some chemicals. There is a temperature difference of 30°C between the air in the room and the freezer. A mist was seen when he opened the freezer door as shown.

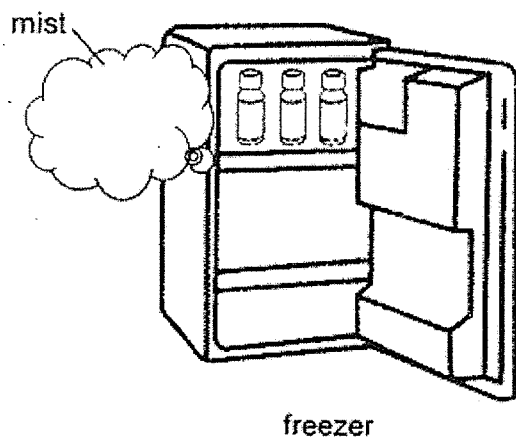

room temperature
at 28°C

- (a) What is the state of matter of the mist? [1]

- (b) Explain how the mist was formed. [2]

- (c) Explain why the mist disappeared after a short time. [1]

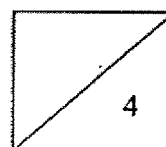

(Go on to the next page)

- 37 Mrs Lin heated up the same volume of water in two identical pots, X and Y. When the water was boiling, she added 1 kg of fishballs into each pot as shown in the diagram below.

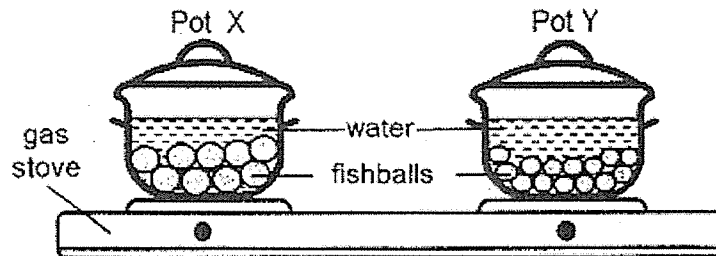

- (a) In which pot, X or Y, would the fishballs take a longer time to cook? Explain your answer.

[1]

After the fishballs were cooked, Mrs Lin scooped five fishballs and soup from Pot Y into two identical bowls, F and G, as shown below. Both bowls of soup were at the same temperature.

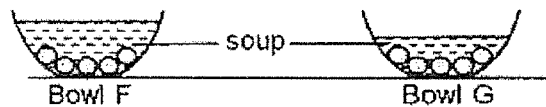

- (b) In which bowl, F or G, would the fishballs soup reach room temperature faster? Explain your answer.

[1]

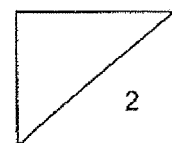

(Go on to the next page)

- 38 The diagram below shows a steel plate attached to a spring in the electric circuit of an electric bell.

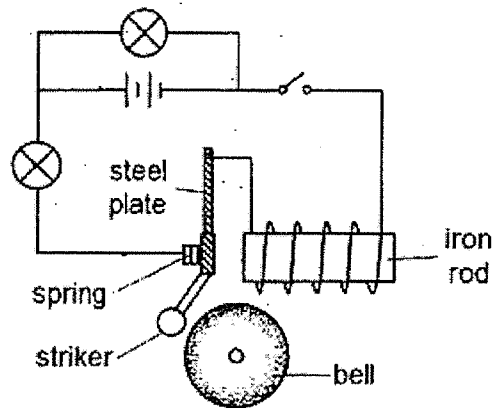

- (a) What type of bulb arrangement is shown in the circuit above? [1]

- (b) Explain how the electric bell works when the switch is closed. [2]

After the steel plate was replaced with object X, the bulbs lit up when the switch was closed but there was no sound heard.

- (c) Based on the above results, state two properties of the material used to make object X. [2]

Property 1: _____

Property 2: _____

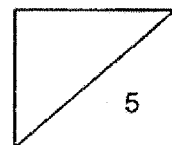

(Go on to the next page)

- 39 Matt played a shooting game at a carnival. He pulled the plunger back to position A. When he pulled the trigger, the plunger would move to position B and a pellet shot forward and hit a toy train. The toy train moved forward.

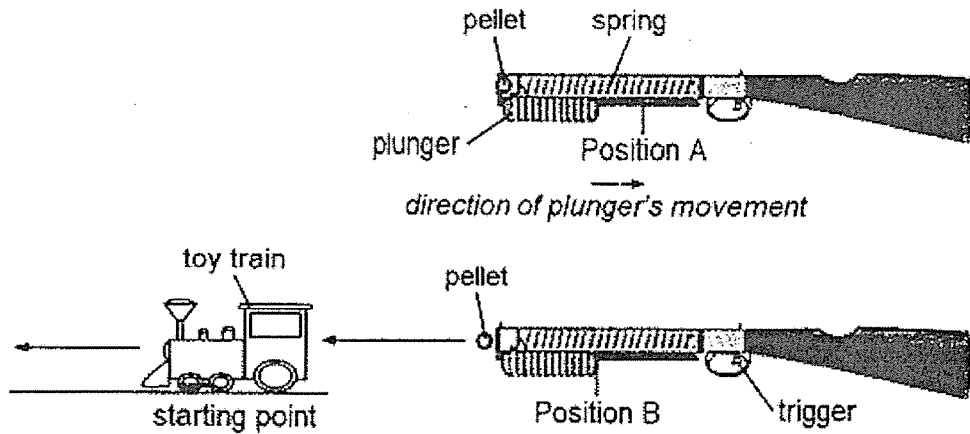

- (a) Trace the energy conversions from when the plunger was pulled back till when the train started moving. Fill in the boxes with the main forms of energy. [2]

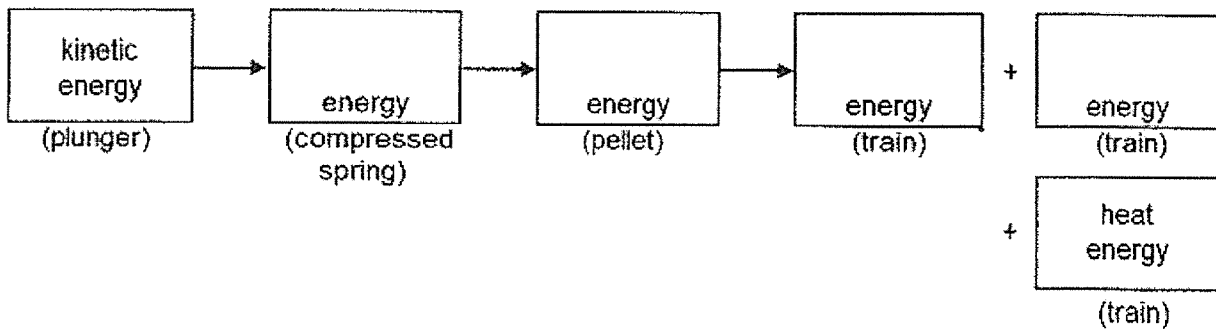

To win a prize, Matt must make the toy train move at least one metre from the starting point. Matt noticed that the toy train moved less than one metre and decided to pull the plunger further back before shooting.

- (b) Explain in terms of energy conversion, how pulling the plunger further back would increase Matt's chances of winning. [2]

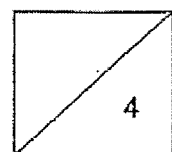

(Go on to the next page)

- 40 Christy set up an experiment using three identical springs. She hung 100 g loads on the springs as shown in the diagram below.

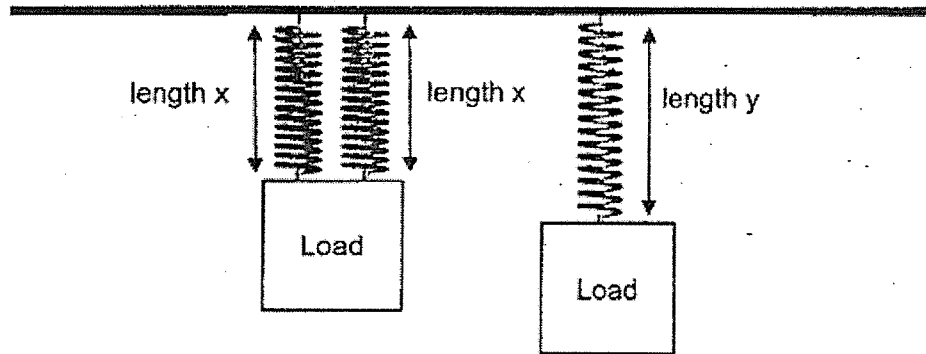

She repeated her experiment using loads of different masses. For each load, she measured length x and y and recorded the results in the table below.

Mass of load (g)	Length x (cm)	Length y (cm)
0	3	3
100	5	7
200	7	8
300	z	10
400	11	13

- (a) When a load of 300 g was hung, state a possible value of z . [1]

_____ cm

- (b) How does using more springs to support a load affect the extension of the spring? [1]

She conducted another experiment by placing 500 g loads onto pieces of cardboard attached to the three identical springs as shown in the diagram below.

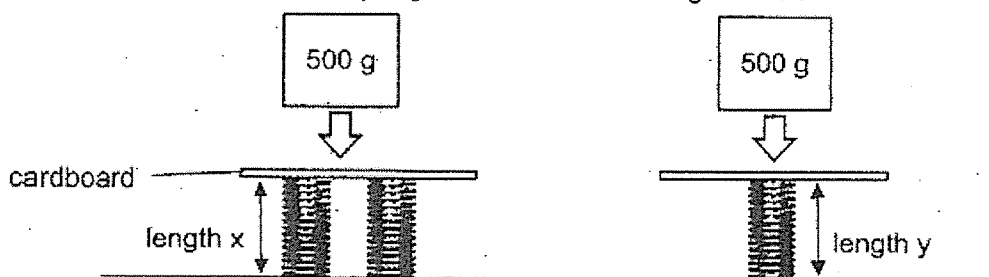

- (c) Name two forces acting on the loads after they were placed on the springs. [1]

Springs are placed under mattresses to provide support for sleepers. Mattresses with stiffer springs provide more support for sleepers with back problems. Three different brands of mattresses, Ace, Bay and Max, are tested by placing a 25 kg mass on each of them.

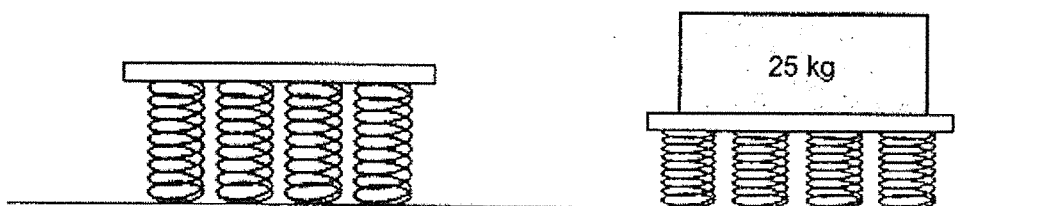

The length of the springs are measured for each mattress and the results are recorded in the table below.

Mattress	Original length of spring (cm)	Length of spring after 25 kg load was placed on it (cm)
Ace	25	20
Bay	25	13
Max	25	16

- (d) Based on the results above, which mattress is most suitable for a person with back problems? Explain your answer using concept of forces. [1]

